

# QUARTZITE

# STONEPEAK

high tech porcelain



The most appealing quartzite is now engineered by StonePeak with an innovative technology which enables us to deliver unprecedented natural looks and textures. StonePeak's Quartzite is a thru-color, rectified line, and is perfect for floor and wall applications in both inside and outside areas.

**StonePeak Ceramics, Inc.**  
**Corporate Headquarters**  
314 West Superior Street  
Chicago, Illinois 60654

**SAMPLEXpress**  
**866-STPEAK1**  
**866-7873251**

**Production Facility**  
238 Porcelain Tile Drive  
Crossville, TN 38555

[www.stonepeakceramics.com](http://www.stonepeakceramics.com)  
[info@stonepeakceramics.com](mailto:info@stonepeakceramics.com)



## COLORS



**Moon**







**Sunset**







**Lime**

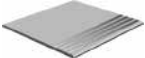

**Iron**

SIZES					
	24"x 12"	24"x 6"	24"x 4"	12"x 12"	12"x 4"
Moon	USG1224096	USG0624096	USG0424096	USG1212096	USG0412096
Sunset	USG1224097	USG0624097	USG0424097	USG1212097	USG0412097
Lime	USG1224098	USG0624098	USG0424098	USG1212098	USG0412098
Iron	USG1224099	USG0624099	USG0424099	USG1212099	USG0412099

TRIMS					
	STAIR TREAD 12"x12"	BULLNOSE 3"x12"	COVE BASE 6"x12"	OUT CORNER 1"x6"	IN CORNER 1"x6"
Moon	USG12ST096	USG312BT96	USG612C096	USG16OC096	USG12IC096
Sunset	USG12ST097	USG312BT97	USG612C097	USG16OC097	USG12IC097
Lime	USG12ST098	USG312BT98	USG612C098	USG16OC098	USG12IC098
Iron	USG12ST099	USG312BT99	USG612C099	USG16OC099	USG12IC099

## MOSAICS

### 12"x12" MOSAIC 2"x2"



USG12MO096  
MOON



USG12MO097  
SUNSET



USG12MO098  
LIME

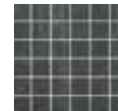

USG12MO099  
IRON

### 12"x24" NEW MOSAIC DESIGN 4



USG124D496  
MOON



USG124D497  
SUNSET



USG124D498  
LIME



USG124D499  
IRON

## PACKAGING INFORMATION

SIZE	PCS/BOX	SF/BOX	THICKNESS (mm)	WEIGHT LBS/SF
12"x24"	8	15.751	8	3.55
6"x24"	16	15.585	8	3.55
4"x24"	18	11.687	8	3.55
12"x12"	10	9.793	8	3.55
4"x12"	36	4.844	8	3.55
12"x12" MOS 2"x2"	5		8	3.55
12"x24" NEW MOS DES 4	4		8	3.55
BULLNOSE	15		8	
COVE BASE	8		8	
STAIR TREAD	10		8	
IN CORNER/OUT CORNER	4		8	

\* All sizes are nominal

\* Printed color reproductions may vary from actual tile color

\* For technical info, please refer to our website [www.stonepeakceramics.com](http://www.stonepeakceramics.com)